



STATE OF ALASKA
DEPARTMENT OF TRANSPORTATION
AND PUBLIC FACILITIES

**TOURIST-ORIENTED
DIRECTIONAL SIGN (TODS) PERMIT**

PERMIT NO. _____

Expiration Date _____

This permit allows the Permittee who owns a tourist-oriented activity to install a sign within a State-owned highway right-of-way that contains the name of the activity and directs the traveling public to the activity. It is subject to all conditions that have been checked by the Department as a requirement on the attached list of conditions.

Permittee:

Business License Number:

Mailing Address:

Contact Name:

E-mail Address:

Phone:

Fax:

MAIN SERVICE OFFERED

GAS FOOD LODGING CAMPGROUND ATTRACTION COMMERCIAL

Location of the Proposed sign installation (includes highway name, milepost or any other information to locate the business):

Property Legal Description (i.e., Lot, Block, Subdivision, Township, Range, Section):

Property Tax ID Number:

Mileage from Highway to Business:

Business within City Limits? Yes No

INTERSECTION INFORMATION

Crossroad Intersection

T-Intersection

Other/Diagram



Existing TODS at this intersection -- business name:

1.	4.
2.	5.
3.	6.

Names and types of tourist-oriented businesses that use the same intersection turn as access to their business as Permittee uses.

BUSINESS NAME	TYPE OF TOURIST-ORIENTED BUSINESS

If a crossroads intersection, all tourist-oriented businesses using the opposite intersecting road for access to their business.

BUSINESS NAME	TYPE OF TOURIST-ORIENTED BUSINESS

SERVICE INFORMATION

Services checked under the applicable category must be offered as a condition of this permit.

Main Service Category

<p>GAS</p> <input type="checkbox"/> Fuel <input type="checkbox"/> Oil <input type="checkbox"/> Free Air & Water <input type="checkbox"/> Public Restrooms <input type="checkbox"/> Public Telephone <input type="checkbox"/> Drinking Water <input type="checkbox"/> Continuous Operation 16 Hours/Day, 7 Days/Week <input type="checkbox"/> Open Year Around <input type="checkbox"/> Located within 3 miles of highway	<p>FOOD</p> <input type="checkbox"/> State License <input type="checkbox"/> Breakfast Daily <input type="checkbox"/> Lunch Daily <input type="checkbox"/> Dinner Daily <input type="checkbox"/> Seat 20 or More <input type="checkbox"/> Public Restrooms <input type="checkbox"/> Public Telephone <input type="checkbox"/> Continuous Operation 16 Hours/Day, 7 Days/Week <input type="checkbox"/> Open Year Around <input type="checkbox"/> Located within 3 miles of highway	<p>LODGING</p> <input type="checkbox"/> State License <input type="checkbox"/> Off-street Parking <input type="checkbox"/> Public Telephone <input type="checkbox"/> 10 Units or More <input type="checkbox"/> Private Bath <input type="checkbox"/> Lodging only service <input type="checkbox"/> Continuous Operation 10 Hours/Day, 7 Days/Week <input type="checkbox"/> Open Year Around <input type="checkbox"/> Located within 3 miles of highway	<p>CAMPING</p> <input type="checkbox"/> State License <input type="checkbox"/> 10 Units or More <input type="checkbox"/> Campsite Parking <input type="checkbox"/> Showers/Toilets <input type="checkbox"/> Drinking Water <input type="checkbox"/> RV Dump Station <input type="checkbox"/> Continuous Operation 24 Hours/Day, 7 Days/Week <input type="checkbox"/> Open 4 Mos./Year <input type="checkbox"/> Located within 25 miles of highway
<p>TOURIST ATTRACTION (Description)</p> <input type="checkbox"/> Major portion of income from non-local motorists <input type="checkbox"/> Continuous operation 8 Hours/Day and 6 Days/Week <input type="checkbox"/> Open at least 4 Months/Year <input type="checkbox"/> Located within 25 miles of Highway		<p>OTHER COMMERCIAL ACTIVITY (Description)</p> <input type="checkbox"/> Major portion of income from non-local motorists <input type="checkbox"/> Continuous operation 8 Hours/Day and 6 Days/Week <input type="checkbox"/> Open at least 4 Months/Year <input type="checkbox"/> Located within 25 miles of Highway	

Recommended Minimum Distance for Advance Placement of TODS Signs	
Posted or 85 th Percentile Speed	Stop Condition
20 mph	N/A
25 mph	N/A
30 mph	100 ft
35 mph	150 ft
40 mph	225 ft
45 mph	300 ft
50 mph	375 ft
55 mph	450 ft
60 mph	550 ft
65 mph	650 ft

Typical condition is the warning of a potential stop situation The distances are based on the 1990 AASHTO Policy for stopping sight distance minus the sign legibility distance of 175 ft.

SIGN INFORMATION



Sign legend:

Mileage for sign legend:

--

14 letters per line ONLY- The spaces counts as one letter. Use abbreviations if more than 14 letters are required per line.

The icon circled on the next page will be used on the sign, unless none is suited. If none is suited, see attached diagram of icon to be used.

COMMONLY USED ICONS
 (Only one icon may be selected per sign.)



ATTACHMENTS INCLUDED AS PART OF THIS PERMIT

FOR ALL TODS:

- Detailed site layout drawing showing:
 - All official traffic signs and devices within 800 feet of location.
 - Proposed TODS location(s) – 200 feet minimum from intersection and any other traffic signs.
 - Business location and access into business.
 - All roads by name, driveways and other pertinent landmarks.

IF APPLICABLE:

- Diagram of icon not shown in the attachment.
- Evidence of approval from applicable government agency (borough, city, etc.) if Trailblazing Signs are required along a road a not owned by the State.

PERMITTEE CERTIFICATION

Permittee upon signing this permit acknowledges and agrees to the conditions made applicable to this permit on the attached list.

I, _____, acknowledge that I am acting on behalf of the above-named Permittee and that I have the full authority to do so. I further acknowledge and accept that the Permittee shall comply will all conditions that the Department of Transportation and Public Facilities has included issuing this permit.

Permittee Signature

Date

PERMIT APPROVAL

DOT&PF Signature

Date

TOURIST ORIENTED DIRECTIONAL SIGNS, TODS, INSTALLATION DETAILS

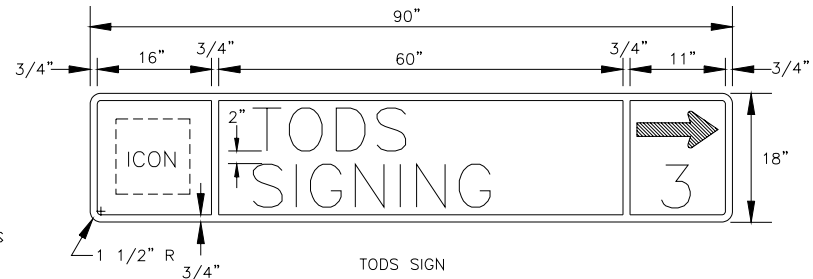
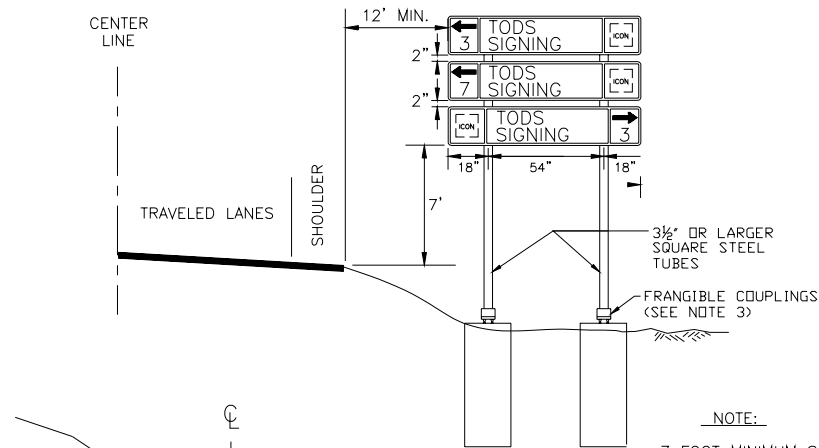

COLORS: Blue Background (Engineer Grade ReflectORIZATION)
 White Legend & Borders (Hi-Intensity ReflectORIZATION)

LETTERS: 6" Upper Case, Series D *

* Use of Series C letters allowed when spacing is a problem.

Message length not to exceed 54 inches. This includes spacing between words on the same line of text.

NOTE:

7 FOOT MINIMUM SPACE BETWEEN THE BOTTOM OF THE SIGN AND THE GROUND BELOW

NOTES:

1. FRAME SIGNS IN ACCORDANCE WITH STANDARD DRAWING S-00.
2. PROVIDE MATERIALS THAT CONFORM TO THE CURRENT EDITION OF THE ALASKA DEPARTMENT OF TRANSPORTATION & PUBLIC FACILITIES STANDARD SPECIFICATIONS FOR HIGHWAY CONSTRUCTION.
3. PROVIDE FRANGIBLE COUPLINGS THAT HAVE PASSED NCHRP 350 TEST LEVEL 3 CRASHWORTHINESS TESTS AND HAVE NO SPECIFIC BOLT TORQUE REQUIREMENTS.
4. PROVIDE SIGN SUPPORTS BE OF SUFFICIENT LENGTH TO ACCOMMODATE THREE TODS SIGN PANELS. PLACE THE FIRST SIGN PANEL IN THE UPPERMOST POSITION WITH THE SECOND AND THIRD PANELS LOCATED IMMEDIATELY BELOW AS SHOWN.
5. PROVIDE SIGN PANELS THAT ARE 0.125 INCH THICK ALUMINUM.
6. ARRANGE SIGNS ON MULTIPLE SIGN INSTALLATIONS ACCORDING TO ARROW DIRECTION. INSTALL SIGNS WITH UP-ARROWS ABOVE THOSE WITH LEFT ARROWS AND THOSE WITH LEFT ARROWS ABOVE THOSE WITH RIGHT ARROWS.

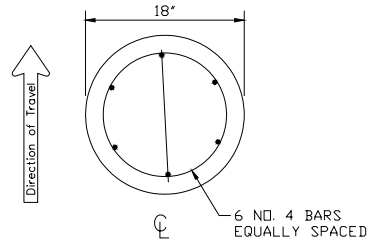
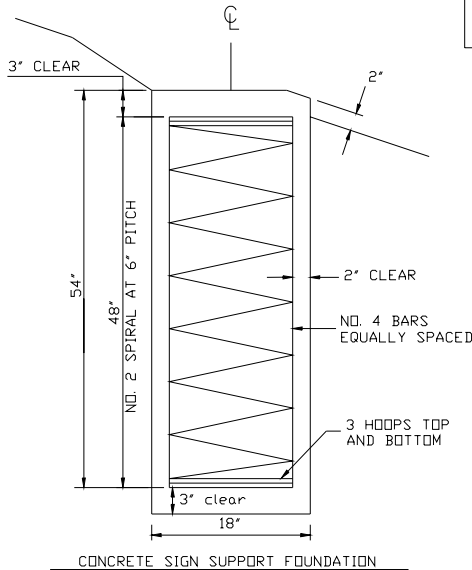

Approved: Kurtis J. Smith Date: 3/29/2002
 State Traffic Engineer
 Alaska Department of Transportation and Public Facilities

**TOURIST-ORIENTED DIRECTIONAL SIGN (TODS)
CONDITIONS APPLICABLE TO THIS PERMIT IF THERE IS AN “X” IN THE
“REQUIRED” COLUMN AT THE TIME THE PERMIT IS ISSUED.**

Required	Item Name	Paragraph
X	Services Offered	All services checked under the Permittee’s Main Service Category in the Services Information portion of this permit must be offered as a condition of this permit.
X	Violation	<p>If any of the conditions of this permit are violated, the State reserves the right to require the removal of the TODS sign. A notice of violation must provide the Permittee with at least 20 days from the date of the notice to remedy the violation.</p> <p>If Permittee fails to remedy a violation, the Department will:</p> <ol style="list-style-type: none"> (1) remove the sign; (2) cancel the permit if it has not already expired; (3) bill the Permittee for the Department’s expenses; (4) within 15 days of the date of removal send a written notice of action to the Permittee; the notice of action must describe the action and the reason for the action; (5) return the sign to the Permittee no later than 15 days after the Permittee pays the Department for its expenses as billed
X	Repair of Damaged Items	If Permittee damages any improvements within the State owned right of way, Permittee will be responsible to return them to their previous condition. The Department’s Maintenance and Operations Section will inspect and approve the restored improvements. Improvements may include but are not limited to: pavement structures, sidewalks, curb and gutter, pathways, driveways, signs, traffic markings, guardrail, delineators, highway lighting systems, traffic signal systems, drainage structures and mailboxes.
X	Hold Harmless	Permittee shall indemnify, defend and hold harmless the State, and its officers, employees, and contractors, from any and all claims or actions resulting from injury, death, loss, or damage sustained by any person or personal property resulting directly or indirectly from Permittee’s placement of the sign.
X	Maintain Facilities	Sign(s) approved by this permit shall be constructed and maintained by the Permittee in such a manner that the highway, and all its appurtenances or facilities including, but not limited to, all drainage facilities, pipes, culverts, and ditches and their safety shall not be impaired in any way by the construction or maintenance.
X	Permit Duration/Renewal	Permit is issued for a period not to exceed five years. Permittee may renew the permit by following the application procedure. A renewed permit expires five years following the date of the current permit. Permittee shall arrange, at their expense, for a sign contractor to remove the sign before the permit expires unless, before the expiration date, the Permittee receives a renewed permit for the sign.
X	Licenses	The Permittee shall maintain the necessary licenses for the TODS activity.
X	Sign Contractor	Upon receipt of a sign permit, Permittee shall arrange, at their expense, for a sign contractor to manufacture, install, and maintain the sign as specified in the permit. A person may not install, maintain, or remove a TODS sign unless the person is named on the Department's list of approved sign contractors. The Department will maintain the list of approved sign contractors. The list consists of those persons known to the Department to have experience in working in public rights of way with active traffic and knowledge of the traffic control requirements necessary for safe operation on an active highway. Before installing, maintaining, or removing a

Required	Item Name	Paragraph
		TODS sign, a sign contractor shall submit a written request for permission to work in the right of way to the Department. The request must include a traffic control plan. The Department will approve the request if the Department, in the Department's discretion, determines that the request is consistent with safe operation on an active highway. In approving the request, the Department will, in the Department's discretion, impose other requirements that are necessary to ensure safe operation.
X	Sign Responsibility	All cost and liability that relate to the sign(s) or their maintenance shall be at the sole expense of the Permittee.
X	Multiple Sign Panels/Set of Posts	Up to three TODS panels may share a set of sign posts. If two or three signs share a set of posts, the Permittees shall share the expense of maintaining the posts.
X	Sign Relocation	The Permittee shall adjust or relocate the sign(s) without cost or liability to the State if, at any time, or from time to time, the use or safety of the highway within which the sign(s) exist requires that they be adjusted or relocated.
X	No Additional Improvements	The Permittee shall not place additional improvements within the right of way, and if, at any time in the future, the permitted sign(s) are destroyed, removed or rebuilt for any reason whatsoever, they shall not again be placed within the right of way unless authorized by another permit. The Permittee shall not install other illegal business signs adjacent to or within the right of way. If additional signs are installed, they will be removed immediately without notice.
X	Business Closure	<p>If the activity associated with this TODS permit is closed, or is expected to be closed, for more than one month, Permittee shall arrange, at their expense, for a sign contractor to remove the sign, or cover it with a plate, not later than 7 days after the date of closure.</p> <p>If the business advertised by this sign permit closes permanently or no longer meets the conditions under which the permit was issued, Permittee shall:</p> <ol style="list-style-type: none"> (1) immediately arrange for a sign contractor to remove the sign not later than 7 days after the closure or change; and (2) not later than 14 days after the closure or change in conditions, send a written notice to the Department describing the closure or change.
X	Change of Business Ownership	If the Permittee transfers the activity associated with this permit to another person or organization, the new owner must notify the Department in writing within 10 days of the transfer. The Department will cancel the original permit and issue, without charge, a comparable permit to the new owner if the Department determines that the material circumstances of the original permit have not changed. The replacement permit expires on the same date that the original permit was expected to expire.
X	Sign Installation Details	Sign shall be installed in accordance with the standard TODS sign detail drawing _____.
X	Permit Subject to Existing Law	This Permit is subject to any applicable federal law, regulations, or policy and procedure memorandum of the Federal Highway Administration (FHWA), and to all applicable state statutes and regulations.
	Trailblazing Signs	Provide trailblazing signs as required by documents listed in 17 AAC 60.915(b). If signs will be located along roads not owned by the State, the applicant must provide evidence of approval from the government agency (borough, city, etc.) responsible for that road.